

LS08-30

Load Shuttle, Ball Type, 207 BAR Rated

A load-shuttling, screw-in, cartridge-style hydraulic check valve, for use in blocking circuits where a priority of flow/direction is given to a higher pressure circuit over a lower one.

Porting	Hydraforce code	Article no.	Price £	Price €
Cartridge Version	LS08-30-0-N25	LS08300C25	£26.00	€31.30
INLINE 1/4" BSP	LS08-30-2B-N25	LS08302B25	£60.40	€72.30
INLINE 3/8" BSP	LS08-30-3B-N25	LS08303B25	£60.40	€72.30

with nitril seals / Viton on request

Materials

Cartridge:

Weight: 0.08 kg. (0.17 lbs.)
Steel with Zinc-plated exposed surfaces.
Buna N O-rings and back-ups standard.

Standard Ported Body:

Weight: 0.27 kg. (0.60 lbs.)
Anodized highstrength 6061 T6 aluminum alloy, rated to 207 bar (3000 psi).
Ductile iron bodies available; dimensions may differ.

Symbols

USASI/ISO:

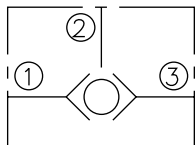

Performance

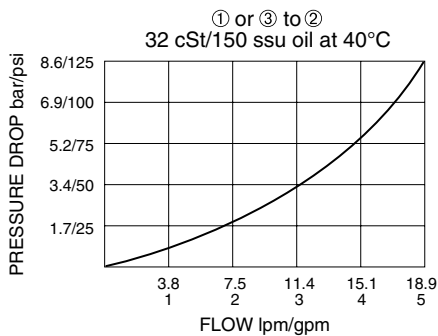

Dimensions

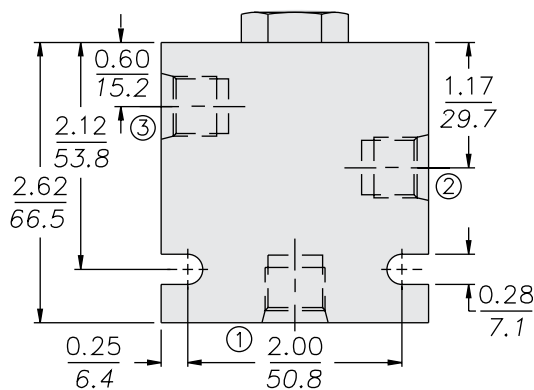
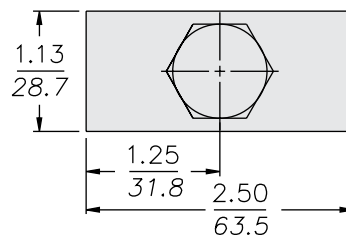
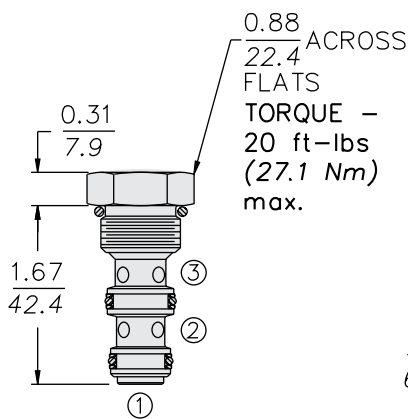

INCH
MILLIMETRE

ORIFICE DISC MAY NOT BE USED WITH THIS PRODUCT.