

2 Way Ball Valve Combinations

BKH Series Price on Application

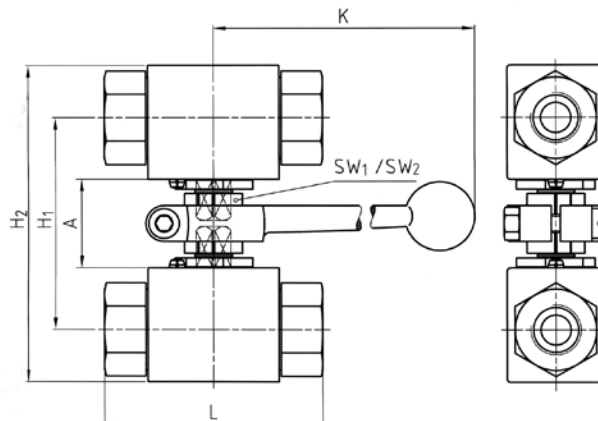

DIN ISO 228 Female thread

Type	DN	L	SW1	SW2	A	H1	H2	K	Lever	Weight kg
BKH-G1/8	4	69	9	14	30	69	96	200	Zn	0,80
BKH-G1/4	6	69	9	14	30	69	96	200	Zn	0,78
BKH-G3/8	10	72	9	14	30	71	106	200	Zn	1,10
BKH-G1/2	13	83	9	14	30	72	110	200	Zn	1,35
BKH-G1/2	16	83	12	17	35	89	127	320	Al	1,45
BKH-G5/8	13	83	9	14	30	72	110	200	Zn	1,35
BKH-G5/8	16	83	12	17	35	89	127	320	Al	1,45
BKH-G3/4	20	95	14	17	39	104	153	320	Al	3,20
BKH-G1	25	113	14	17	39	110	169	320	Al	4,50
BKH-G1 1/4	25/32	120	14	17	39	110	169	320	Al	4,80
BKH-G1 1/2	25/40	130	14	17	39	110	169	320	Al	5,40

MKH Series Price on Application

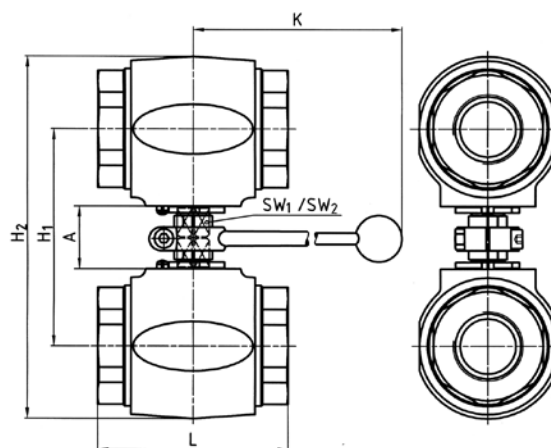

DIN ISO 228 Female thread

Type	DN	L	SW1	SW2	A	H1	H2	K	Lever	Weight kg
MKH-G1 1/4	32	111	17	19	43	134	215	320	Al	6,40
MKH-G1 1/2	40	130	17	19	43	149	249	320	Al	10,60
MKH-G2	50	140	17	19	43	159	277	320	Al	15,00

These products are not 'PED Compliant' for use with GAS

Should you have a GAS application please contact our sales office in order that they can check the PED requirements and offer a CE marked suitable product.