

# Counterbalance Valves - T11A 2:1

## Adjustable Setting

- Turn adjustment clockwise to increase setting
- Backpressure at port 2 adds to the effective relief setting at a ratio of 1 plus the pilot ratio times the backpressure
- Set your counterbalance valve at least 1.3 times the maximum load induced pressure
- This valve is not provided with positive seals on the pilot section
- Declared reseal value is obtained with valve set @ maximum setting

## Technical Details

Cavity	T11A
Capacity	60 lpm (16 gpm)
Max operating pressure	350 bar
Pilot ratio	2:1
Maximum setting	350 bar (5000 psi)
Minimum setting	35 bar (500 psi)
Pressure increase per turn	206 bar (spring D) - 132 bar (spring M) - 33 bar (spring T)
Pressure setting established @	cracking pressure (1in3/min)
Maximum valve leakage at reseal	5 drops / minute
Operating characteristic	standard
Reseat	>85%
Maximum recommended load pressure at maximum setting	270 bar (3900 psi)
Valve hex size	19
Valve installation torque	40-45 Nm (30-35 lbf ft)
Adjustment screw internal hex size	4
Seal-lock hex size	13
Seal-lock torque	12-15 Nm (9-11 lbf ft)
Valve weight	0.150 Kg (0.33 lbs)
External component surface treatment	zinc plating + sealing
Seal kit (nbr)	S00T11ASN900000
Seal kit (viton)	S00T11ASV900000
Temp range	-30 to 100°C (-22 to 212°F) with BunaN seals;
Fluids	Mineral-based or synthetics with lubricating properties at viscosities of 10 to 500 mm <sup>2</sup> /s (cSt)
Filtration	Nominal value max. 10µm (NAS 8) / ISO 4406 19/17/20



HYDRAULIC VALVES

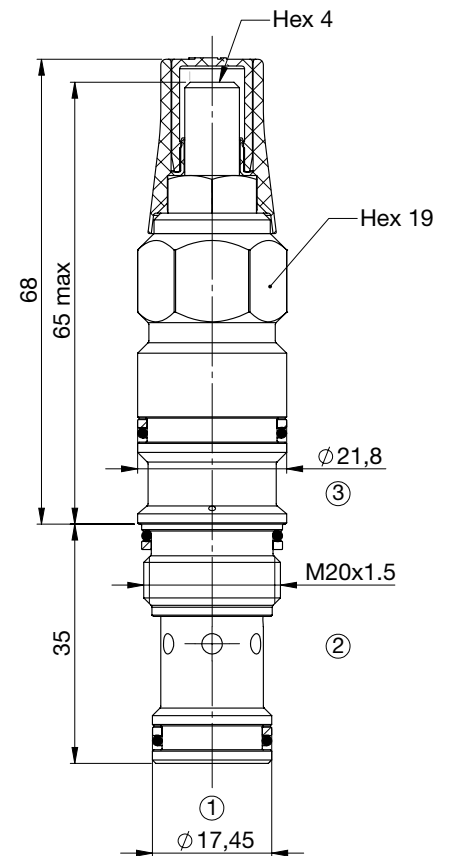
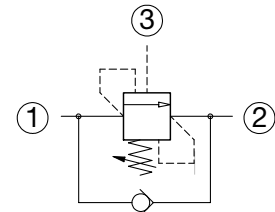

## Performance Curves

